

SUB-ASSEMBLY SHOWN AS SHIPPED SUB-ASSEMBLY SHOWN IN FINAL POSITION

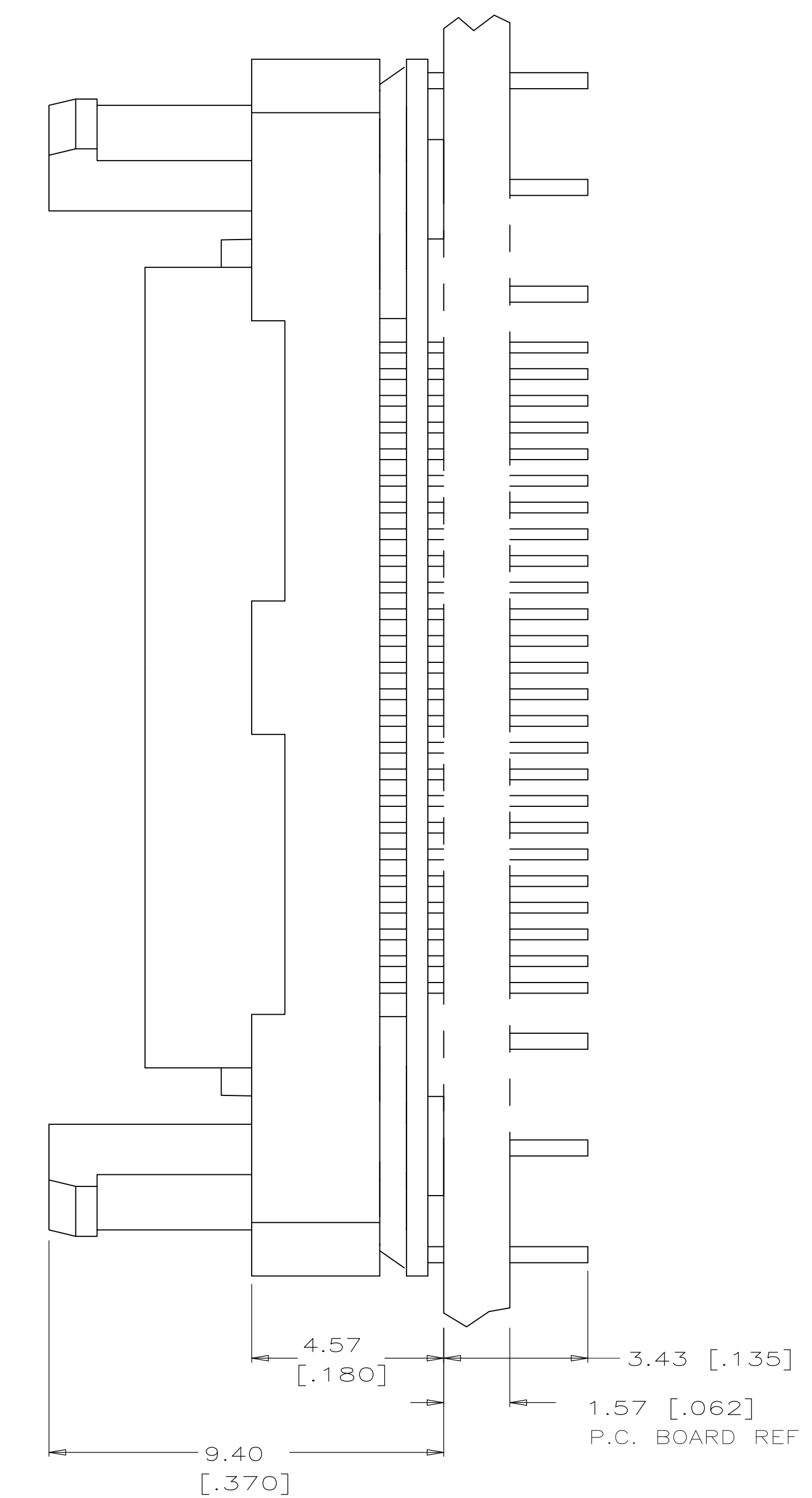
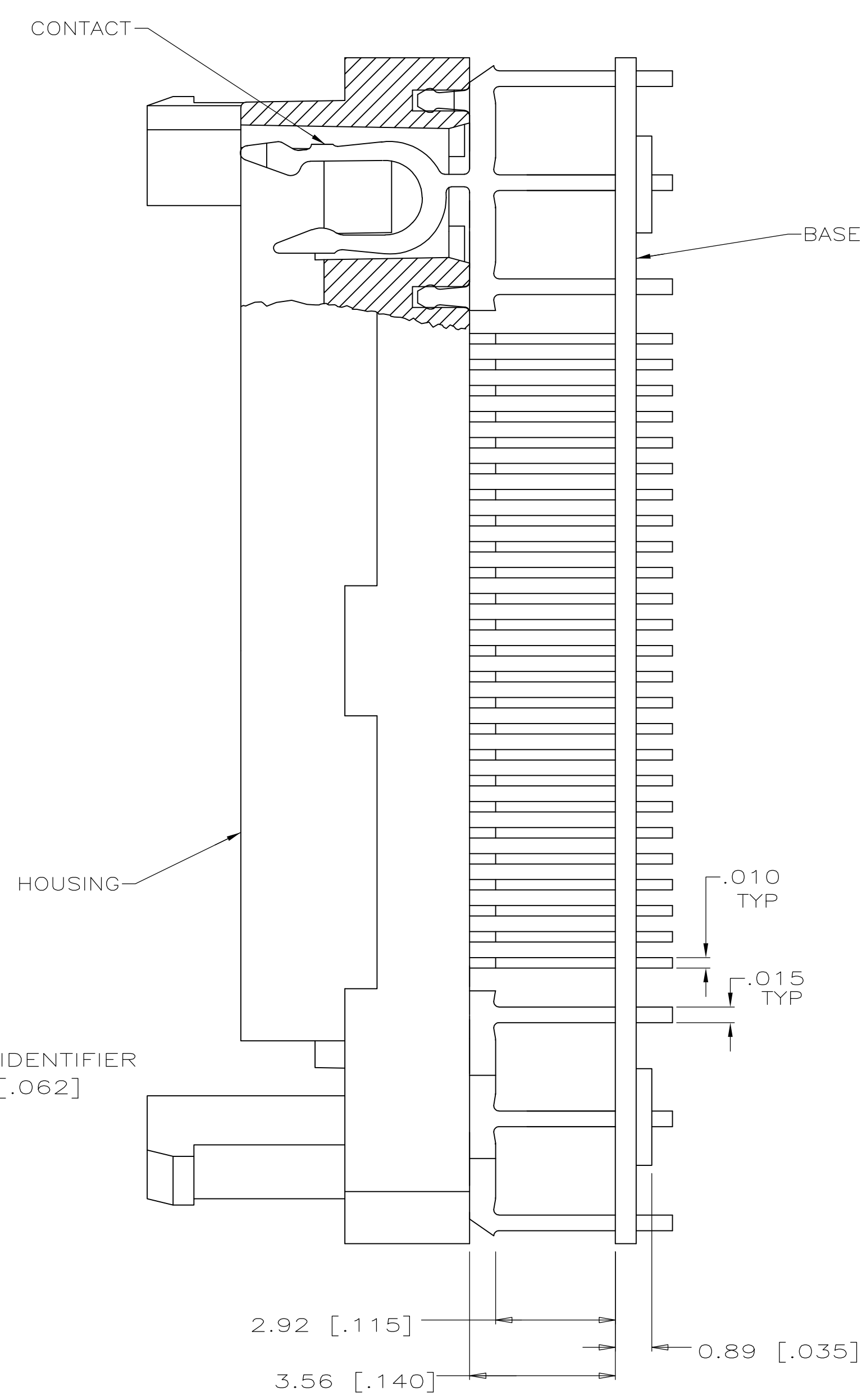

- ① HOUSING MATERIAL SHALL BE LIQUID CRYSTAL POLYMER. (BLACK)
- ② CONTACT MATERIAL SHALL BE PHOS. BRONZE. PLATING SHALL BE 0.00508 [.000200] MIN. TIN LEAD OVER 0.00127 [.000050] MIN. NICKEL ALL OVER.
- ③ BASE MATERIAL SHALL BE LIQUID CRYSTAL POLYMER. (BLACK)
- ④ SOCKET TO BE MOUNTED WITH AMP LOGO AND CHAMFER ON SOCKET LOCATED IN THIS CORNER OF P.C. BOARD.
- ⑤ THIS AREA TO BE FREE OF COMPONENTS FOR ACCESS OF THE MICRO-PITCH HAND TOOL. MINIMUM OF TWO OPPOSITE SIDES.
- ⑥ CONTACT MATERIAL SHALL BE PHOS. BRONZE. PLATING SHALL BE 0.00508 [.000200] MIN. TIN (LEAD FREE) OVER 0.00127 [.000050] MIN. NICKEL ALL OVER.
- ⑦ ROHS 2002/95/EC COMPLIANT.

⑦⑥	20.32 [.800]	34.04 [1.340]	2-821949-5	132
⑦⑥	15.24 [.600]	28.96 [1.140]	2-821949-4	100
②	20.32 [.800]	34.04 [1.340]	821949-5	132
②	15.24 [.600]	28.96 [1.140]	821949-4	100
FINISH	B	A	PART NO.	NO OF POSN

THIS DRAWING IS A CONTROLLED DOCUMENT.

DIMENSIONS: INCHES	TOLERANCES UNLESS OTHERWISE SPECIFIED:	DWN: K.SALMON 10-4-90	TE Connectivity
0 PLC ± -	1 PLC ± -	CHK: R.MILLER 10-5-90	
2 PLC ± -	3 PLC ± 0.1[.005]	APVD: F.BOYD 10-5-90	NAME: MICRO-PITCH SOCKET .025 C/L PQFP GULLWING, HOUSING SUB-ASSEMBLY
4 PLC ± -	ANGLES ± -	APPLICATION SPEC	SIZE: A1
MATERIAL	FINISH	WEIGHT	CAGE CODE: 00779
①②③⑥	②⑥	CUSTOMER DRAWING	DRAWING NO: 821949

SCALE: 10:1 SHEET 1 OF 3 REV N1

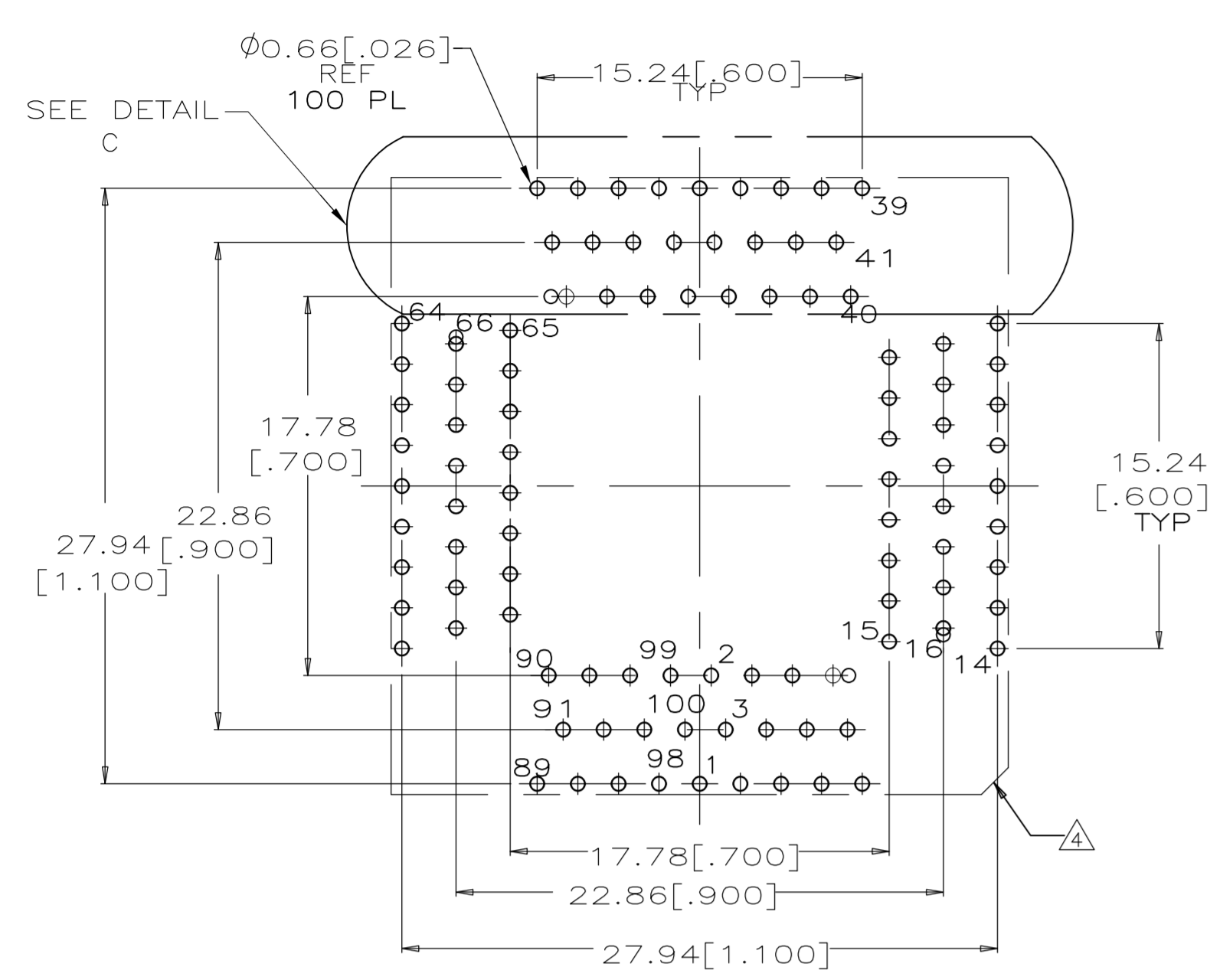

RECOMMENDED P.C. BOARD HOLE PATTERN
 SOCKET SIDE
 100 POSN.
 SCALE: 4:1

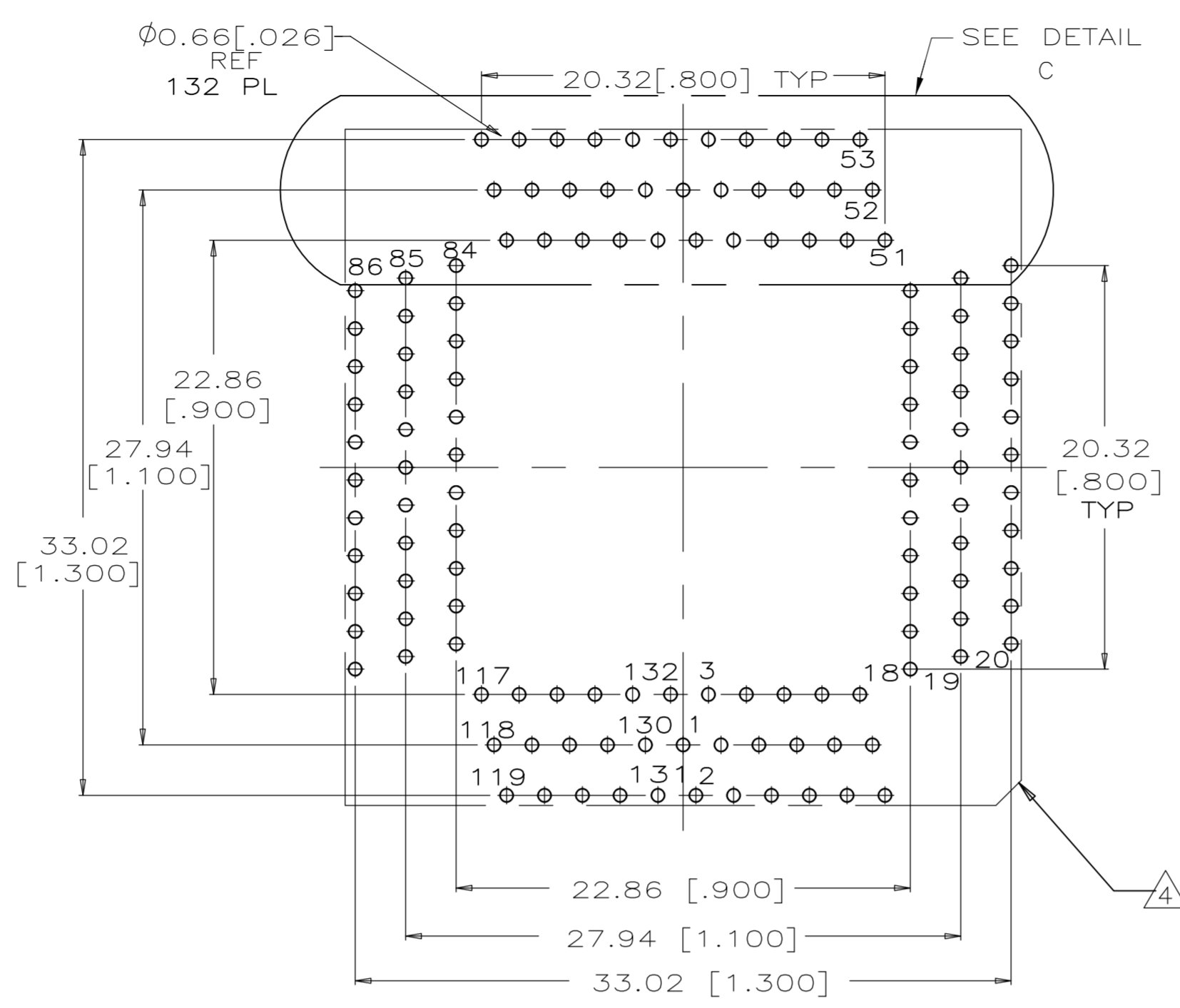

RECOMMENDED P.C. BOARD HOLE PATTERN
 SOCKET SIDE
 132 POSN.
 SCALE: 4:1

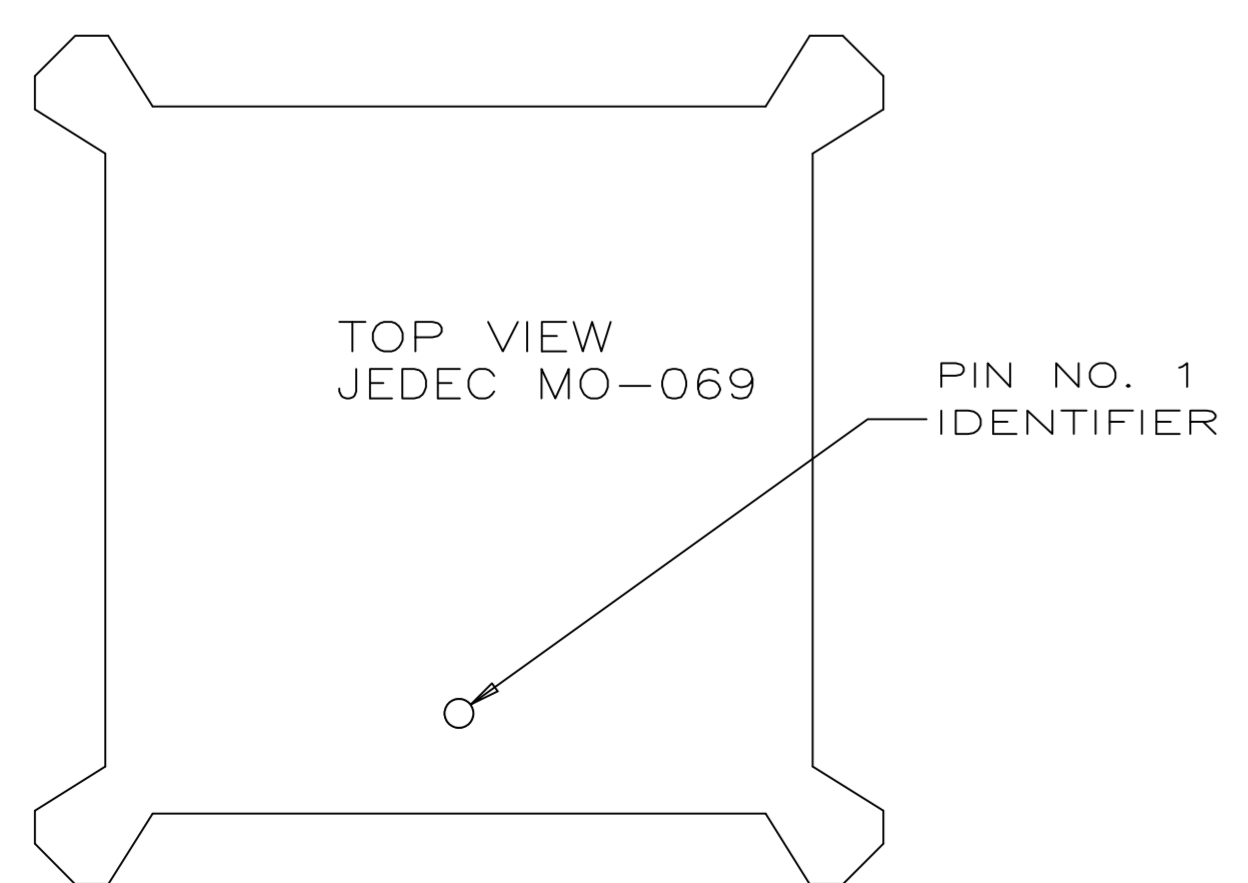

CHIP POLARIZATION REFERENCE VIEW
 (PIN NUMBERING ON THIS SHEET ARE FOR
 CENTER LOCATION OF PIN 1 IDENTIFIER)

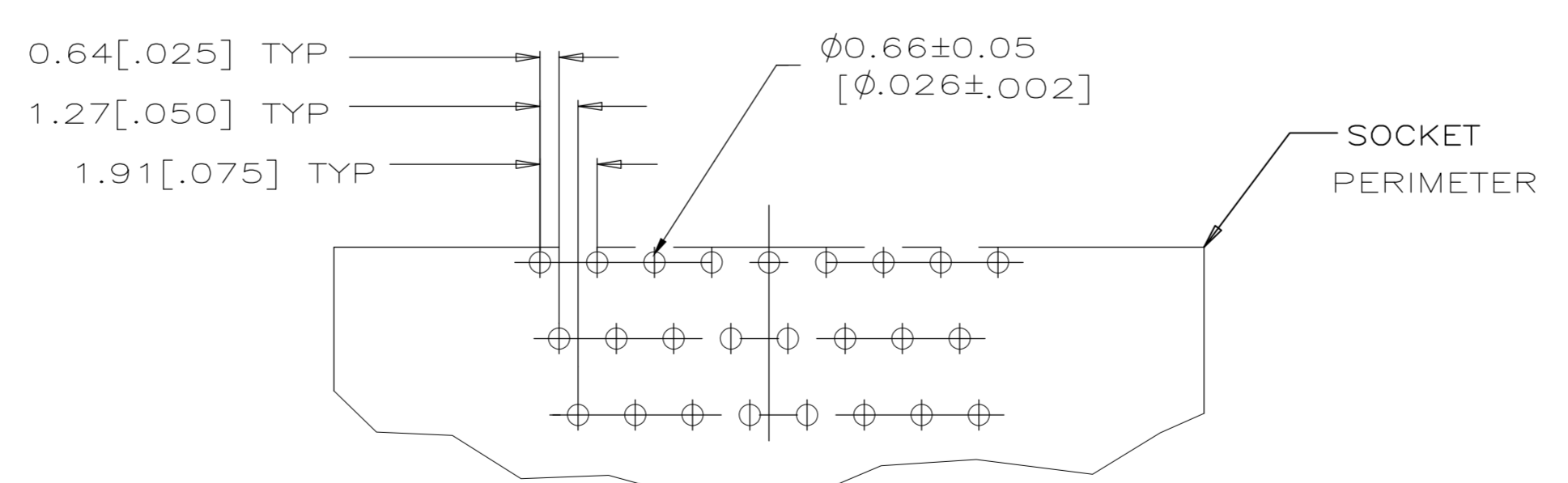

DETAIL C
 (TYP FOR ALL POSITIONS)
 SCALE 5:1

THIS DRAWING IS A CONTROLLED DOCUMENT.		DWN K. SALMON 10-4-90	TE Connectivity
DIMENSIONS: INCHES		CHK R. MILLER 10-5-90	
TOLERANCES UNLESS OTHERWISE SPECIFIED:		APVD F. BOYD 10-5-90	NAME MICRO-PITCH SOCKET .025 C/L, PQFP GULLWING, HOUSING SUB-ASSEMBLY
0 PL C ± - 1 PL C ± - 2 PL C ± - 3 PL C ± 0.1 ± [0.005] 4 PL C ± - ANGLES ± -		APPLICATION SPEC	RESTRICTED TO
MATERIAL	FINISH	WEIGHT	SIZE A1 00779 C=821949
CUSTOMER DRAWING		SCALE 10:1	SHEET 2 OF 3 REV N1

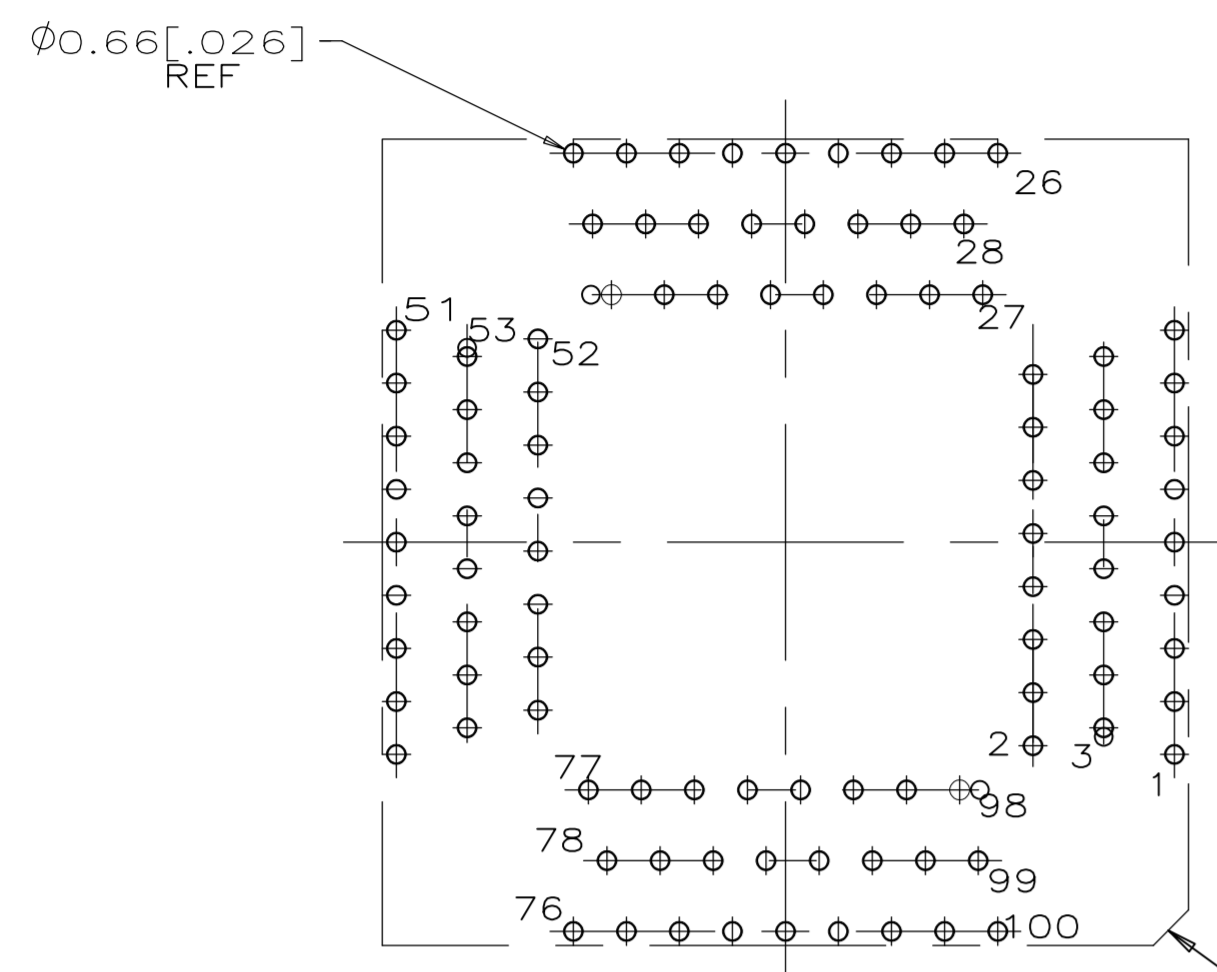

RECOMMENDED P.C. BOARD HOLE PATTERN
 SOCKET SIDE
 100 POSN.
 SEE SHEET 2 100 POSN FOR DIMENSIONS

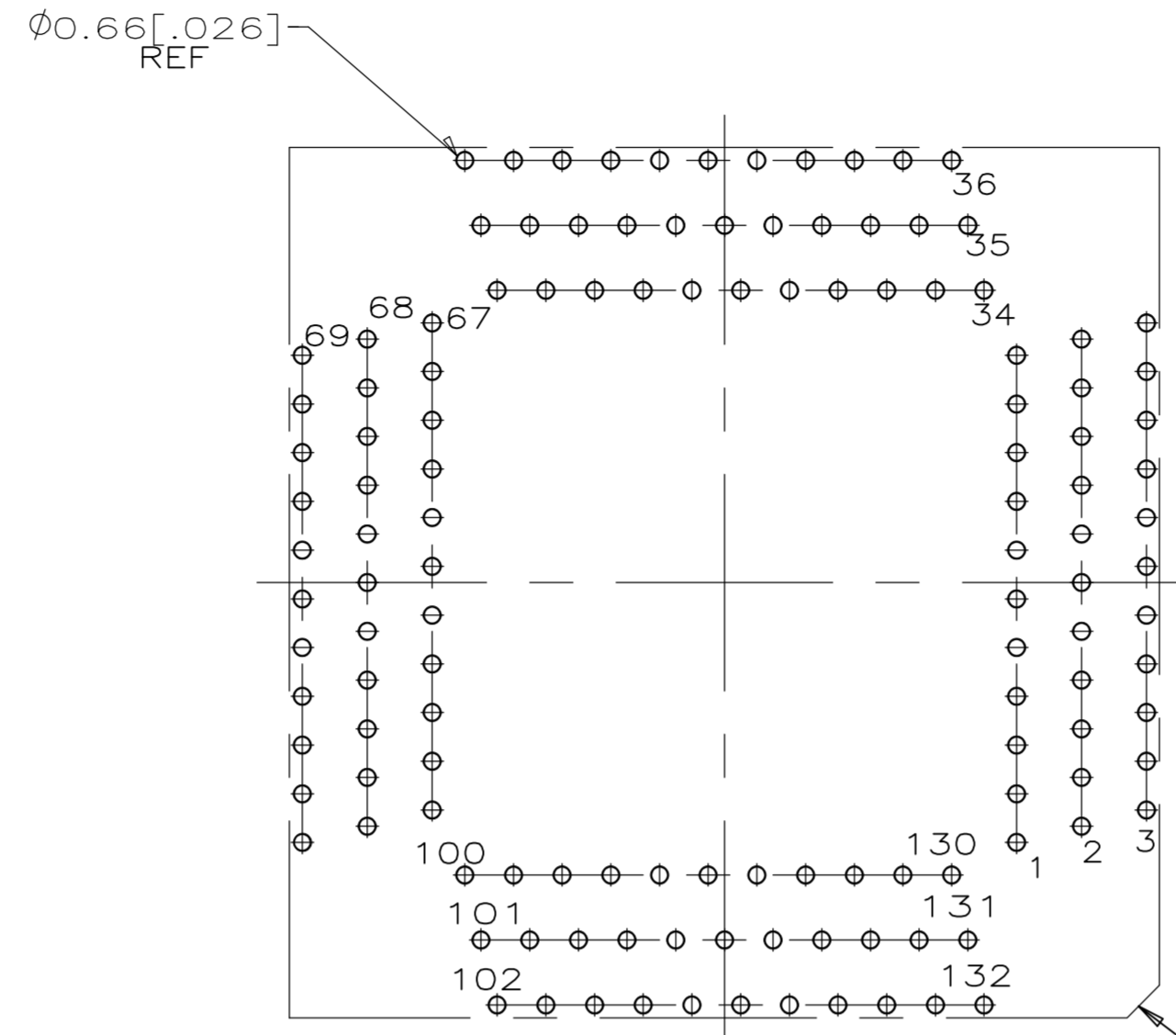

RECOMMENDED P.C. BOARD HOLE PATTERN
 SOCKET SIDE
 132 POSN.
 SEE SHEET 2 132 POSN FOR DIMENSIONS

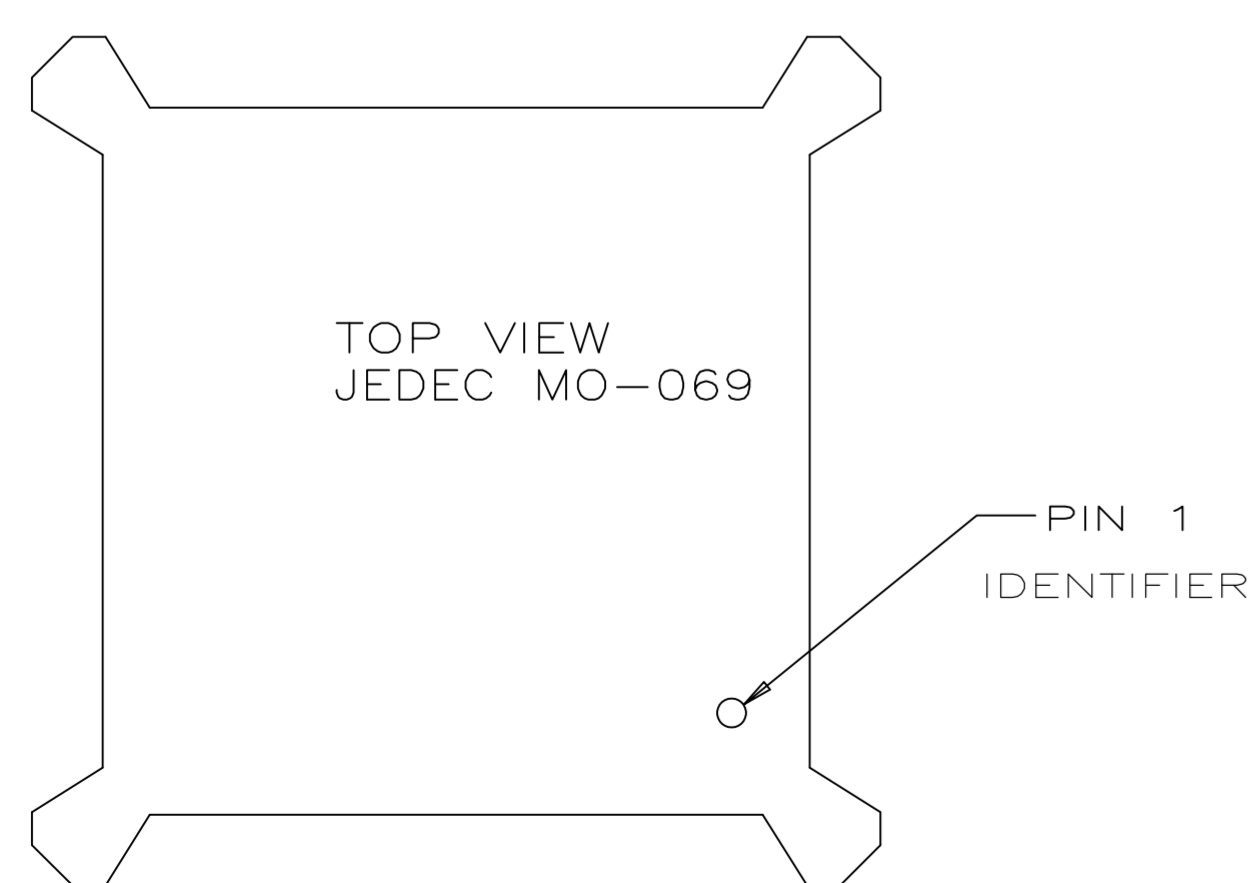

CHIP POLARIZATION REFERENCE VIEW
 (PIN NUMBERING ON THIS SHEET IS FOR OFF CENTER LOCATION OF PIN 1 IDENTIFIER)

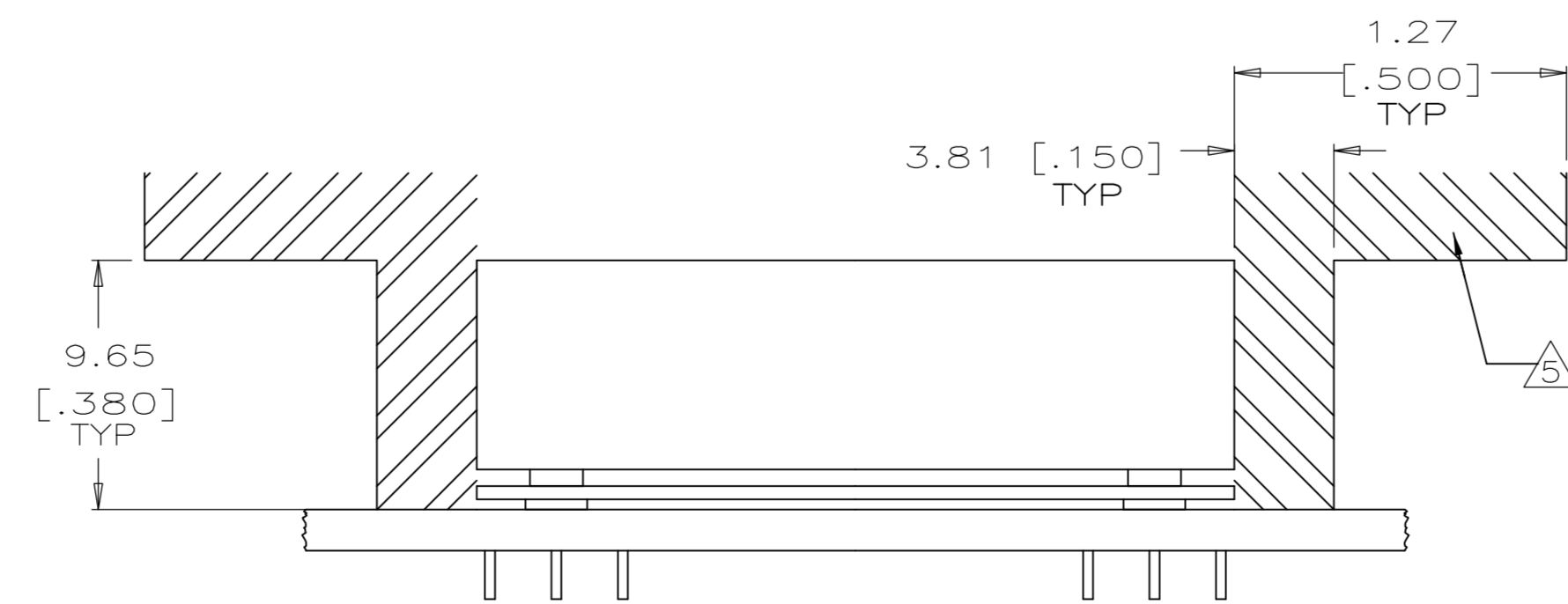

MICRO-PITCH SOCKET

THIS DRAWING IS A CONTROLLED DOCUMENT.		DWG K. SALMON 10-4-90	TE Connectivity
DIMENSIONS: INCHES		CHK R. MILLER 10-5-90	
TOLERANCES UNLESS OTHERWISE SPECIFIED:		APPV F. BOYD 10-5-90	NAME MICRO-PITCH SOCKET
0 PL C	± -	PRODUCT SPEC	.025 C/L PQFP GULLWING, HOUSING SUB-ASSEMBLY
1 PL C	± -	APPLICATION SPEC	SIZE CAGE CODE DRAWING NO
2 PL C	± -	RESTRICTED TO	A1 00779 C=821949
3 PL C	± 0.12 [.005]	WEIGHT	—
4 PL C	± -	CUSTOMER DRAWING	SCALE 10:1 SHEET 3 OF 3 REV N1
ANGLES	± -		
MATERIAL			
FINISH			